

ColecoVision

The ColecoVision is a second-generation video-game console produced by Coleco Industries. It retailed for \$174.99 and had a Zilog Z80 CPU at 3.58 MHz with 8KB of RAM. Due to poor sales of the console (maybe related to the video-game crash in North America) Coleco Industries filed for bankruptcy soon after. It was notable for providing a close-to-arcade experiences for some games. Masayuki Uemura, head of Famicom development, stated that the ColecoVision set the bar that influenced how he approached the creation of the Famicom.



Coleco released the Expansion Module #1 that allowed the ColecoVision to play Atari 2600. [Atari did not like this](#), settling out of court with Coleco to be licensed under Atari's patents.

The Expansion Module #3 would be released that would convert the ColecoVision into the [Coleco Adam home computer](#).

This system scrapes metadata for the colecovision group(s) and loads the colecovision set from the currently selected theme, if available.

Quick reference

- **Emulator:** libretro/bluemsx
- **Folder:** /userdata/roms/colecovision
- **Accepted ROM formats:** .bin .col .rom .zip .7z

BIOS

MD5 checksum	Share file path	Description
--------------	-----------------	-------------



ROMs

Place your ColecoVision ROMs in /userdata/roms/colecovision.

Emulators

RetroArch

[RetroArch](#) (formerly SSNES), is a ubiquitous frontend that can run multiple “cores”, which are essentially the emulators themselves. The most common cores use the [libretro](#) API, so that's why cores run in RetroArch in Batocera are referred to as “libretro/(core name)”. RetroArch aims to unify the feature set of all libretro cores and offer a universal, familiar interface independent of platform.

RetroArch configuration

RetroArch offers a **Quick Menu** accessed by pressing [HOTKEY] +  which can be used to alter various things like [RetroArch and core options](#), and [controller mapping](#). Most RetroArch related settings can be altered from Batocera's EmulationStation.

Standardized features available to all cores of this emulator: `colecovision.videomode`, `colecovision.ratio`, `colecovision.smooth`, `colecovision.shaders`, `colecovision.pixel_perfect`, `colecovision.decoration`, `colecovision.game_translation`

ES setting name batocera.conf key	Description ⇒ ES option key value
Settings that apply to all cores of this emulator	
GRAPHICS BACKEND <code>colecovision.gfxbackend</code>	Choose your graphics rendering ⇒ OpenGL <code>opengl</code> , Vulkan <code>vulkan</code> .
AUDIO LATENCY <code>colecovision.audio_latency</code>	Audio latency in milliseconds, turn it up if you hear crackles ⇒ 256 256, 192 192, 128 128, 64 64, 32 32, 16 16, 8 8.

libretro/Bluemsx

libretro/Bluemsx configuration

ES setting name batocera.conf key	Description ⇒ ES option key value
Settings that apply to all systems this core supports	
REDUCE SPRITE FLICKERING <code>colecovision.bluemsx_nospritelimits</code>	Remove the 4 sprite per line limit ⇒ Off <code>False</code> , On <code>True</code> .

Controls

The default button mapping for the ColecoVision's controls is as follows:

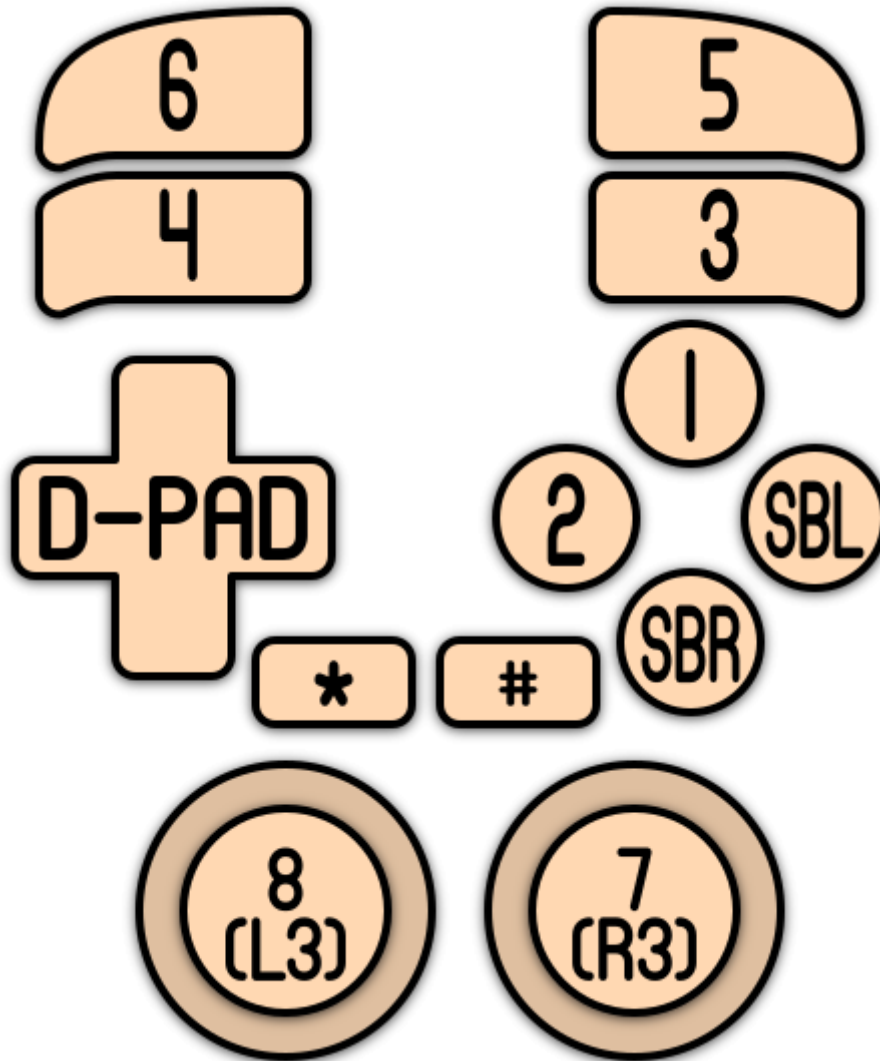

Troubleshooting

For further troubleshooting, refer to the [generic support pages](#).

From: <https://wiki.batocera.org/> - **Batocera.linux** - Wiki

Permanent link: <https://wiki.batocera.org/systems:colecovision?rev=1637648321>

Last update: **2021/11/23 06:18**

